

> We are DEVELON

We trace our roots to 1937 as one of Korea's first large scale machine plant. Throughout time we have consistently delivered exceptional products and solutions.

DEVELON is a bold name that reflects our core ambition to continue developing onwards and leaving behind a positive footprint in our world. Moving forward, we seek to be part of our customers and partners' endeavor to build a better world.

Powered by **Innovation**



©2023 HD Hyundai Infracore. All rights reserved.
HDIPBE-01-2307

Certain specification(s) are based on engineering calculations and are not actual measurements. Specification(s) are provided for comparison purposes only and are subject to change without notice. Specification(s) for your individual Develon equipment will vary based on normal variations in design, manufacturing, operating conditions, and other factors. Pictures of Develon units may show other than standard equipment

develon-ce.com

DEVELON

SD Wheel Loaders

SD200 SD300 SD300H



Photos may include optional equipment

SD200

SOLID-BASED, SPORTY PLAYER

BALANCED POWER, TUNED EFFICIENCY

- Ideal operating speed and 40-degree steering angle, sharply improve work efficiency.
- SD200 armed with stronger breakout force and tractive force, reflecting its excellent performance in a high-load working environment.

BUILT FOR ALL CONDITION

- Reasonable matched technology, ensures a more reliable and durable equipment.
- Industry leading cooling system, guarantees continuous and uninterrupted work under high temperatures.

ALL AROUND SAFETY AND COMFORT

- Noise reduction technology complying with international standards provides protection and boosts work efficiency.
- Newly designed cabin is spacious and provides wider view and enhanced comfort.



SD200 CERTIFIED PERFORMANCE



ENGINE (WP6G125E22)

The perfect blend of efficiency and power. The Weichai engine produces 92 kW at 2,200 rpm. High power and appropriate torque range enables to precisely deliver the stable working speed.

SD200 REINFORCED DURABILITY

SOLID FRAME STRUCTURE

3D CAD and FEM technologies are adopted in the analysis of technical design. Improving the strength, durability and reliability of the device.

PROVEN DURABILITY

SD200's working attachments and articulated pin are properly matched in size and are optimally positioned in force bearing area.

TRANSMISSION SHAFT

Double bearing supporting propeller shaft in dual configuration improves machine's reliability. Lubricating oil can be infused easily, enhancing the durability.

ALUMINUM RADIATOR

SD200 used aluminum radiator, which is stronger and guarantees better quality than copper, enhancing the machine reliability.

COOLING PERFORMANCE

The patented cooling system offers continuous and uninterrupted work under high temperatures.

EASY MAINTENANCE

ENGINE COVER

Engine cover part is integrated in one-piece. United cover makes it easy to repair engine and sub parts.

EASY APPROACH

Both sides of the hood can be opened to the side. Making daily oil inspection and maintenance works quicker and more convenient.

CONVENIENT INSPECTION ON HYDRAULIC LEVEL

Monitoring the hydraulic oil level was made easier, to reduce maintenance time and to improve device service lifetime.

HIGHLY EFFICIENT COOLING FAN

The cooling fan made up of varied sized blades, efficiently reduces noise and increases air flow.

QUICKLY CHANGEABLE BREAK DISCS

The use of quick-change brake discs allows the user to check brake pads for excessive wear at any time and change the brake pads more easily without removing the tires.

OUTDOOR POWER SWITCH

To enhance maintenance safety and convenience, power switch is equipped on outdoor to cut off battery power when needed.



SD200

WELCOMING AND PERSONAL SPACE

CABIN COMFORT

Ample space, wide visual field and intuitive features will guarantee a pleasant work. Noise inside cabin is lower, comfortable working space with multi angle adjustable steering wheel.

AIR FLOW INCREASED BY 30%

Offering high-performance air conditioning system, electronically controlled according to the environmental conditions.

NEW OPERATOR PANEL

The new instrument gauge panel has been changed simple and intuitively to put essential information right in front of the operator.

ERGONOMICALLY DESIGNED PEDAL

The adjusted pedal angle relieves the pressure on ankle and joints, reducing operator's fatigue.

LED LAMP FOR IMPROVED VISIBILITY

Existing front lamp has been upgraded to LED and totally six more lights have been added. Two additional LED lights and cables on the front and four more on the back.

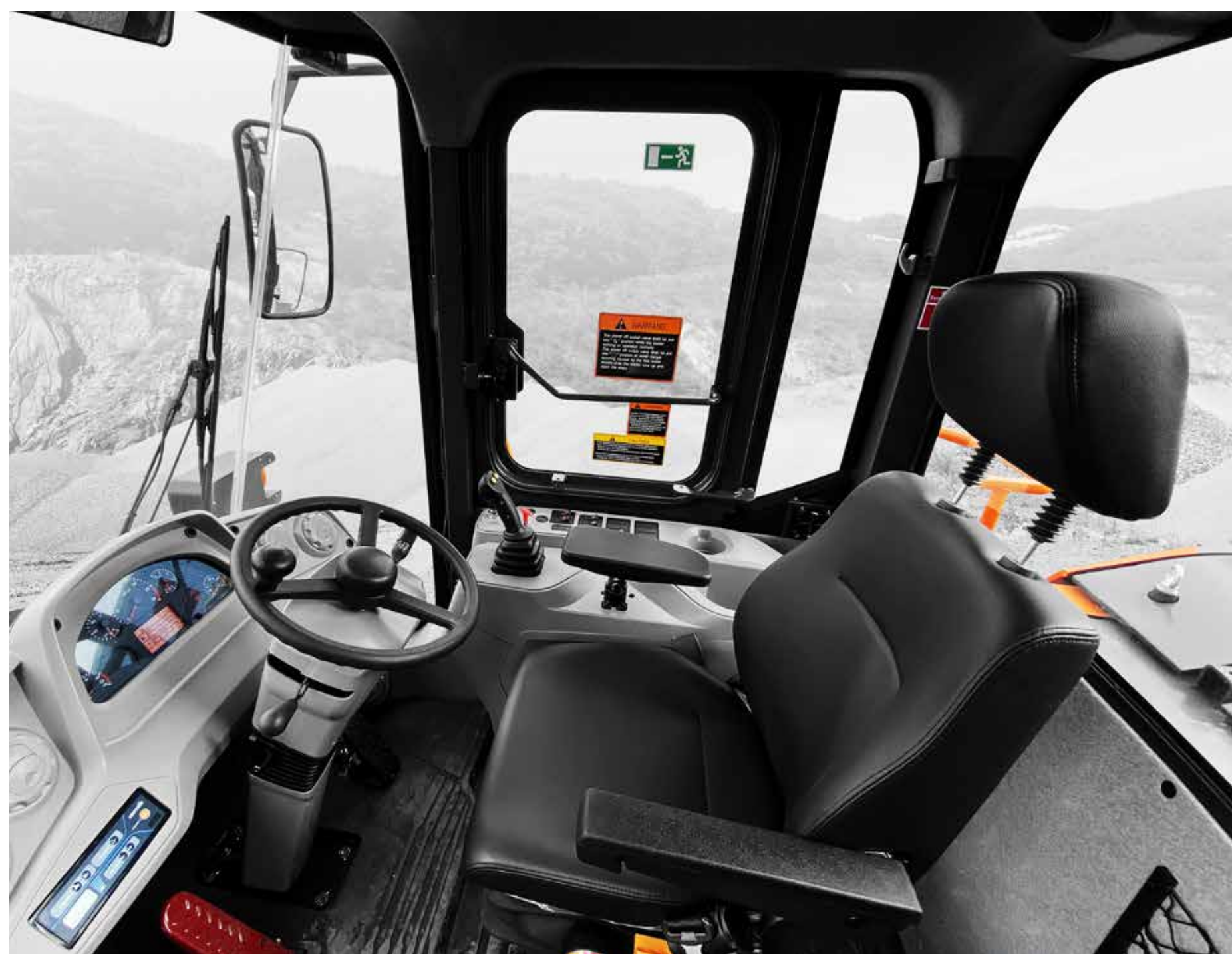

BRIGHT AND VERSATILE, WITH ACCELERATED PERFORMANCE

- Reasonable match between transmission and torque converter fully play engine power enable the whole machine to deliver stronger traction.
- With 3,200mm wheelbase and 5,630mm turning radius, SD300 is specially designed for light materials. It enables greater agility and more efficient operation.

RELIABLE PARTNER WITH EFFICIENT COOLING SYSTEM

- The advanced drive axle and improved differential bevel gear have increased gear flexural strength, which enhances the reliability of the drive axle and extending its lifespan.
- By using Develon patented technology and a redesigned layout with materials, the cooling system significantly reduces hydraulic oil and water temperature during operation.

WELL-APPOINTED INTERIOR AND WELL SECURED SAFETY

- Noise reduction technology complying with international standards provides protection and boosts work efficiency.
- Newly designed cabin is spacious and provides wider view and enhanced comfort.

SD300

PROPELLING HELPER PREPARING ALL THE WAY



SD300

RIGHT PERFORMANCE IN RIGHT PACE

PERFECTLY MATCHED POWER TRAIN

Engine, transmission and axles are optimized and finely tuned for each other and produce powerful traction.

SMALLER TURNING RADIUS AND AGILITY

Larger steering angle (40°) makes smaller turning radius. Small turning radius offers flexibility for operator to adapt in a confined space.

ACCELERATION PERFORMANCE

The injection pump has undergone special test and features greatly improved engine acceleration performance and speed.

SHORTENED HYDRAULIC SYSTEM ACTION TIME

Short system action time leads to a shorter operation cycle and greater efficiency.



ENGINE (WD10G220E23)

Greater engine outputs of 162kw and impressive torque enables to precisely deliver the power you need. The fitted engine has been adjusted to various condition and offers lower fuel consumption in commonly used operating states.

SD300

REINFORCED DURABILITY

DURABLE AXLE DESIGN

More durable materials and technology were applied to machining gears.

REINFORCED PINS

The hinge pins for operating devices in 6 positions have a radius of 5-10mm larger than similar products in the industry.

SOLID FRAME STRUCTURE

3D CAD and FEM technologies are adopted in the analysis of technical design. Improving the strength, durability and reliability of the device.

SOLID MAIN CONTROL VALVE

New pilot main control valve, which lowers inside leak and prolongs the service life. A pilot filter is added to increase the reliability of pilot system.

SWING FRAME CONNECTION

Connecting parts of swing frame adopt a reinforced design to offer greater strength.

TRANSMISSION SHAFT

Double bearing supporting propeller shaft in dual configuration. Lubricating oil can be infused easily, enhancing the durability.

BOX SHAPED

Rear frame side plates' box-shaped structure allows enhanced frame strength.

EASY MAINTENANCE

ENGINE COVER

Engine cover part is integrated in one-piece. United cover makes it easy to repair engine and sub parts.

LCD PANEL FOR ERROR CODE

LCD panel in the gauge panel shows error code and operator can recognize failures of the machine.

EASILY CHANGEABLE BREAK DISCS

The use of quick-change brake discs allows the user to check brake pads for excessive wear at any time and change the brake pads more easily without removing the tires.

BOOSTER BUMP

The booster pump delivers a higher augmented-thrust ratio and more stable braking performance.

EASY APPROACH

Both sides of the hood can be opened to the side. Making daily oil inspection and maintenance works quicker and more convenient.

CONVENIENT INSPECTION ON HYDRAULIC LEVEL

Monitoring the hydraulic oil level was made easier, to reduce maintenance time and to improve device service lifetime.



SD300 OPTIMIZED WORKSPACE

CABIN COMFORT

Ample space, wide visual field and intuitive features will guarantee a pleasant work. Cabin also offers significant noise and vibration reduction.

LED LAMP FOR IMPROVED VISIBILITY

Existing front lamp has been upgraded to LED and totally six more lights have been added. Two additional LED lights and cables on the front and four more on the back.

ENTERTAINMENT SYSTEM

MP3+radio, SD card and USB slot add enjoyment to operator's work conditions.

SHOCK PAD

A new model of shock pad is used to provide stronger durability and reduced shock and noise, effectively relieving the operator's fatigue.

ALL AROUND VISIBILITY

Improved visibility on the bottom section of the front windshield enables easy positioning of front wheels.

DELUXE SEAT

High back, deep-seated position, dual armrests and multi-level spring shock absorption guarantee a comfortable operation.

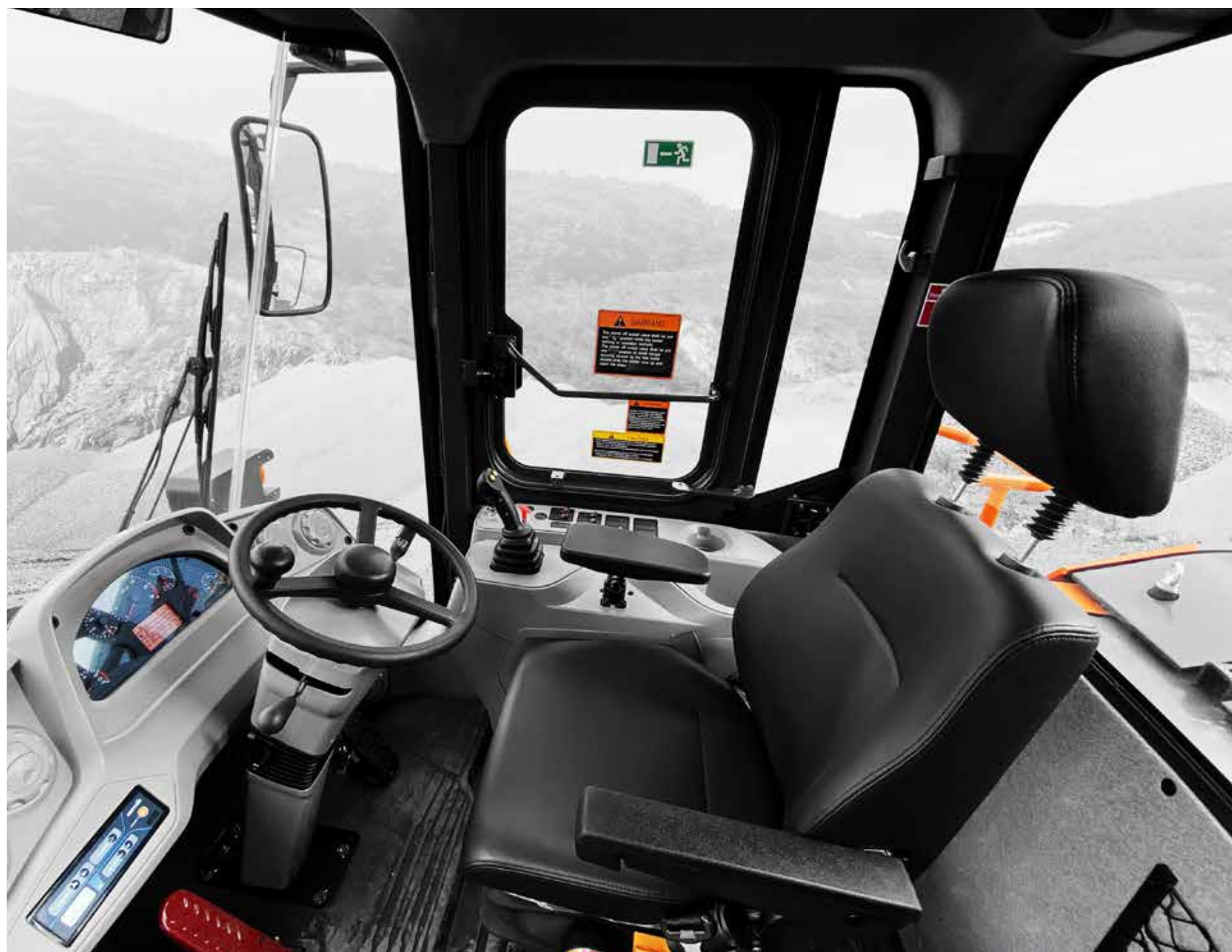



SD300H

PROACTIVE SOLUTION YOU NEEDED

ENERGY EFFICIENT

- Advanced hydraulic system conduct efficient work, fully utilizing pump with the dual pump confluence technology.
- Minimal shift shock and excellent power transmission by applying ZF automatic power-shift transmission.

HIGH RELIABILITY

- High strength structure with the adoption of stress calculation and strict quality testing ensure that all our components and parts are safe and reliable.
- Wear-resistant materials are used for the bucket and robust design applied upper parts of the bucket.
- All hydraulic cylinder O-rings and hydraulic hoses use high quality brand parts, increasing hydraulic system reliability.

DESIGN & COMFORTABILITY

- Interior of the cabin features an ergonomic design comprising a large operational space, a wide visual field and a user-friendly control unit.

SD300H FORERUNNER OF EFFICIENCY

ACCELERATION PERFORMANCE

The injection pump and features have undergone special test and greatly improved engine acceleration performance and speed.

ENERGY SAVING HYDRAULIC PARTS

High quality hydraulic steering unit efficiently arranges the surplus hydraulic oil to working units depending on working condition.

TRANSMISSION BOX WITH TORQUE CONVERTER

The ZF automatic transmission box with electro-hydraulic control is applied, and 4 forward and 3 reverse multi-gear functions can meet the needs of different working conditions. It matched perfectly with engine and the traction 14% higher than the industry average with easier shovel operations and increased efficiency.

COOLING SYSTEM

SD300H's unique patented cooling technology greatly reduces hydraulic oil and coolant temperature during the machine's operation time, thus resolving the high temperature problem.



ENGINE (WD10G220E23)

High output of 162 kW is produced by 2,000 rpm. Improving fuel efficiency by using lower rated RPM than competitors. This also reduces engine noise and increases durability.



SD300H HIGH DURABILITY

SOLID FRAME STRUCTURE

High strength steel is used for structural parts and stress calculation by using FEM software is carried out so as to ensure that the strength of structural parts may meet the requirements under the worst and heaviest working conditions.

DURABLE AXLE DESIGN

More durable materials and technology were applied to machining gears.

TRANSMISSION SHAFT

Double bearing supporting propeller shaft in dual configuration. Lubricating oil can be infused easily, enhancing the durability.

PRE-HEATER

Added engine preheating device and the enlarged CCA(Cold Cranking Amperes) capacity make it easy to start the motor in low-temperature environments.

SOLID MAIN CONTROL VALVE

New pilot main control valve, which lowers inside leak and prolongs the service life. A pilot filter is added to increase the reliability of pilot system.

EASY MAINTENANCE

FULLY ACCESSIBLE ENGINE COVER

Excellent maintainability and ground access by applying gull wing type engine covers with wide opening.

QUICKLY CHANGEABLE BREAK DISCS

The use of quick-change brake discs allows the user to check brake pads for excessive wear at any time and change the brake pads more easily without removing the tires.

LCD PANEL FOR ERROR CODE

LCD panel in the gauge panel shows error code and operator can recognize failures of the machine.

CONVENIENT INSPECTION ON HYDRAULIC LEVEL

Monitoring the hydraulic oil level has made easier, window applied for convenient oil inspection.

FUEL TANK

The fuel tank is placed on the rear. Thick plates are applied, which significantly reduce the rate of damages caused by collision.

SD300H **BALANCE OF FUNCTION** **FOR OPERATOR CONCENTRATION**

CABIN COMFORT

Ample space, wide visual field and intuitive features will guarantee a pleasant work. Noise inside cabin is lower, comfortable working space with multi angle adjustable steering wheel.

AIR FLOW INCREASED BY 30%

Offering high-performance air conditioning system, electronically controlled according to the environmental conditions.

NEW OPERATOR PANEL

The new instrument gauge panel has been changed simple and intuitively to put essential information right in front of the operator.

LOWER NOISE

SD300H's cabin offers a quiet and comfortable working environment and improved work efficiency.

LED LAMP FOR IMPROVED VISIBILITY

Existing front lamp has been upgraded to LED and totally six more lights have been added. Two additional LED lights and cables on the front and four more on the back.

ERGONOMICALLY DESIGNED PEDAL

The adjusted pedal angle relieves the pressure on ankle and joints, reducing operator's fatigue.

ALL AROUND VISIBILITY

Improved visibility to the Left and right bottom section of the front windshield for easy positioning of front wheels.

DELUXE SEAT

High back, deep-seated position, dual armrests and multi-level spring shock absorption guarantee a comfortable operation.

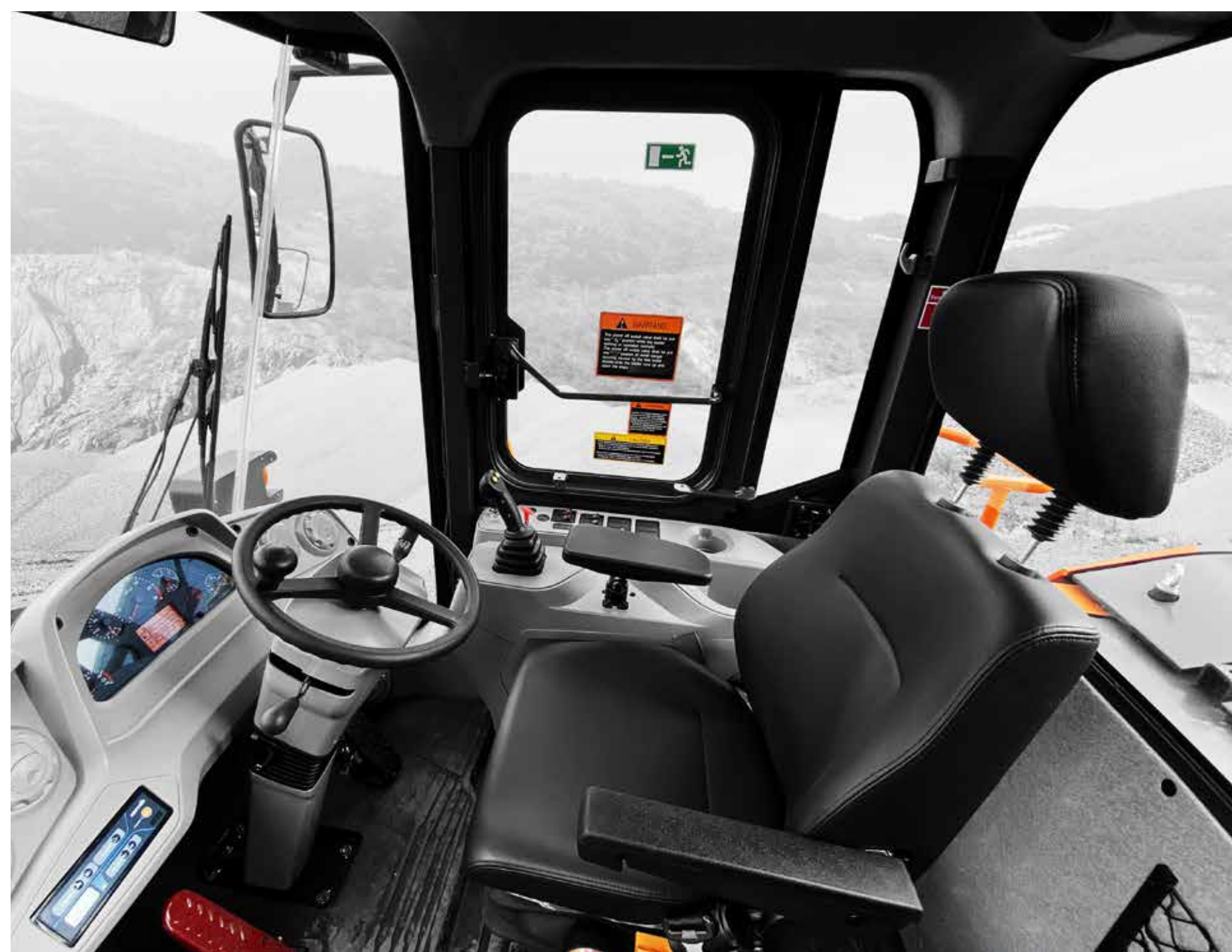

TECHNICAL SPECIFICATION (SD200)

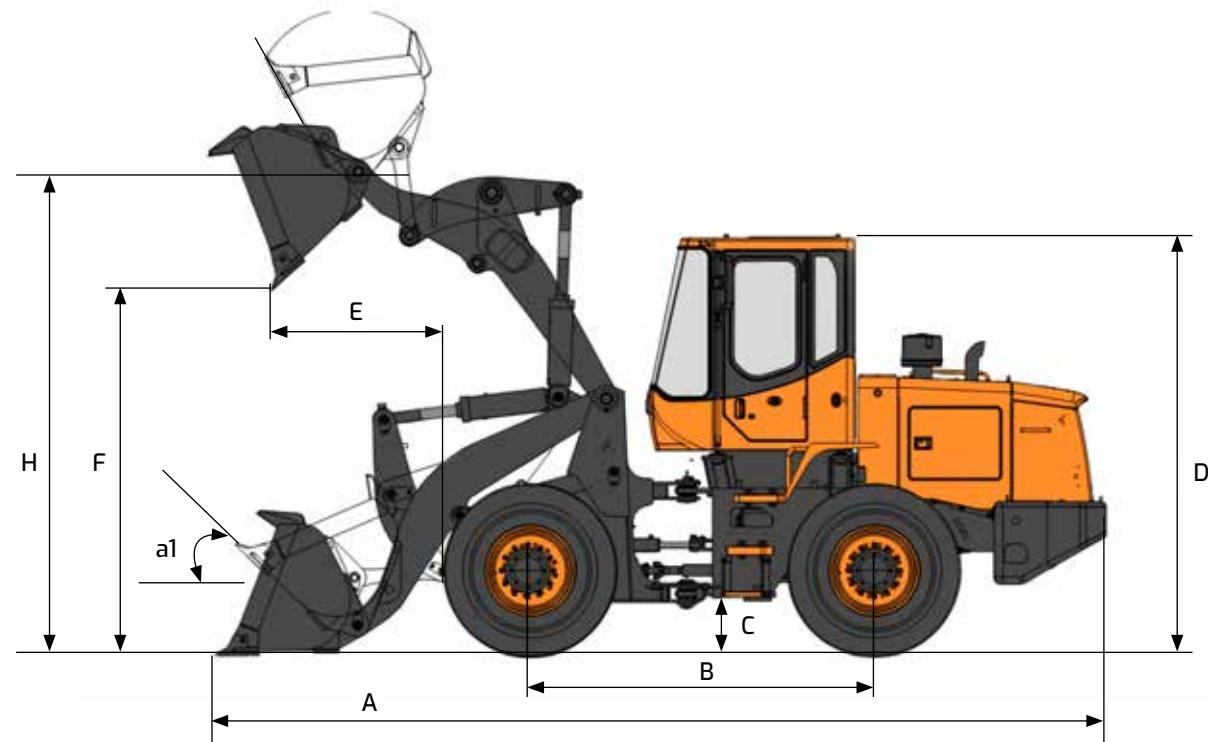

ENGINE

| | |
|-----------------------------------|-----------------------------|
| Model | Weichai WP6G125E22 (TIER 2) |
| Rated Power (SAE J1995 Gross) | 92 kW (125 ps)@2,200 rpm |
| Max. Torque (SAE J1995 Gross) | 500 N.m@1,400-1,500 rpm |
| Number of cylinders/bores/strokes | 6 / 105 mm / 130 mm |
| Displacement | 6.7 L |

TRANSMISSION

| | |
|-----------------------------------|---|
| Type | 4 Speed, Power-shift, Countershaft, engine remote mounted with propeller shaft & damper |
| Torque Converter Stall Ratio/Size | 3.2 / 315 mm |

HYDRAULIC SYSTEM

| | |
|------------------------|------------|
| Main Pump Type | Fixed gear |
| Main Pump Displacement | 100 cc/rev |
| Max. Flow Rate | 215 l/min |

GENERAL SPECIFICATIONS

| | |
|---|-------------------------------|
| Operating Weight | 10.4 ton |
| Bucket Capacity (SAE HEAPED) | 1.7 m ³ |
| Payload | 3 ton |
| Travel Speed (1/2/3/4) | 8.5 / 13.0 / 24.0 / 37.0 km/h |
| Static Tipping Load (straight) | 8,000 kg |
| System Pressure (Work/Steer) | 170/140 kg/cm ² |
| Sound Level in CAB (2000/14/EC) | 84 dB (A) |
| External Sound Power Level (2000/14/EC) | 112 dB (A) |
| Fuel Tank Capacity | 150 L |
| Tire Size | 17.5 - 25 - 12 PR |

DIMENSIONS & WORKING RANGE (SD200)

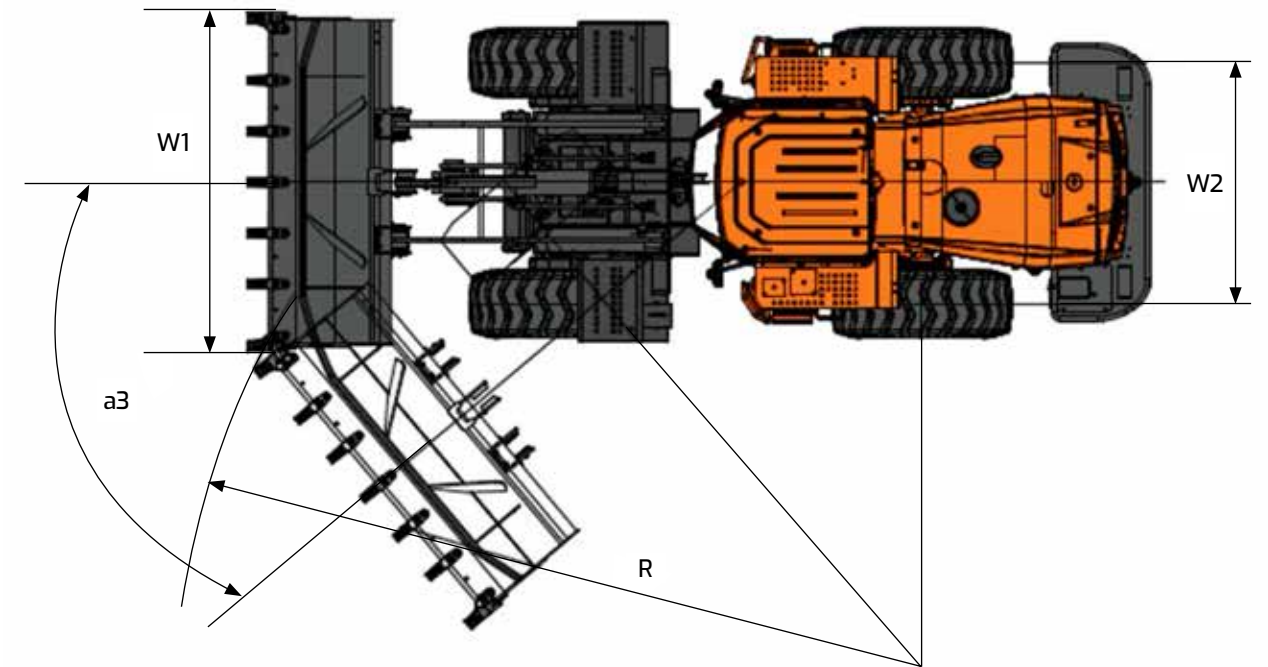

| ITEMS | UNIT | STD. | OPT 1 | OPT 2 | OPT 3 | | |
|-----------------------------------|------------------|---------------------------------|------------|-------|---------|---------|-------|
| Operating Weight | ton | 10.4 | 10.5 | 10.6 | 10.6 | | |
| Bucket Capacity (SAE HEAPED) | m ³ | 1.7 | 1.7 | 2.2 | 2.2 | | |
| Arm | | STD. | LONG | STD. | STD. | | |
| Breakout Force | kN | 99 | | | | | |
| Dimension | Overall Length | A | mm | 6,950 | 7,138 | 7,007.5 | 7,165 |
| | Overall Width | W1 | mm | 2,496 | 2,496 | 2,496 | 2,496 |
| | Overall Height | D | mm | 3,350 | 3,350 | 3,350 | 3,350 |
| | Ground Clearance | C | mm | 350 | 350 | 350 | 350 |
| | Wheelbase | B | mm | 2,830 | 2,830 | 2,830 | 2,830 |
| | Tread | W2 | mm | 1,850 | 1,850 | 1,850 | 1,850 |
| | Working Range | Dump Height at 45° (with tooth) | F | mm | 2,815 | 3,109 | 2,775 |
| Dump Reach at 45° (with tooth) | | E | mm | 1,195 | 1,066.5 | 1,186 | 1,057 |
| Max. Tilt Angle (on ground) | | | degree (°) | 45 | 45 | 45 | 45 |
| Max. Tilt Angle (at fully raised) | | | degree (°) | 61 | 60 | 63 | 60 |
| Height at bucket pivot point | | H | mm | 3,740 | 4,028 | 3,740 | 4,028 |
| Max. Tilt Angle (at carry) | | a1 | degree (°) | 50 | 50 | 50 | 50 |
| Digging Depth (0° level) | | | mm | 55 | 72 | 54 | 42 |
| Max. Steering Angle | | a3 | degree (°) | 40 | 40 | 40 | 40 |
| Turning Radius (tire center) | | | mm | 5,090 | 5,090 | 5,090 | 5,090 |
| External radius at bucket edge | | R | mm | 5,710 | | | |
| Gradeability | % (°) | 58 (30) | | | | | |

TECHNICAL SPECIFICATION (SD300)

DIMENSIONS & WORKING RANGE (SD300)

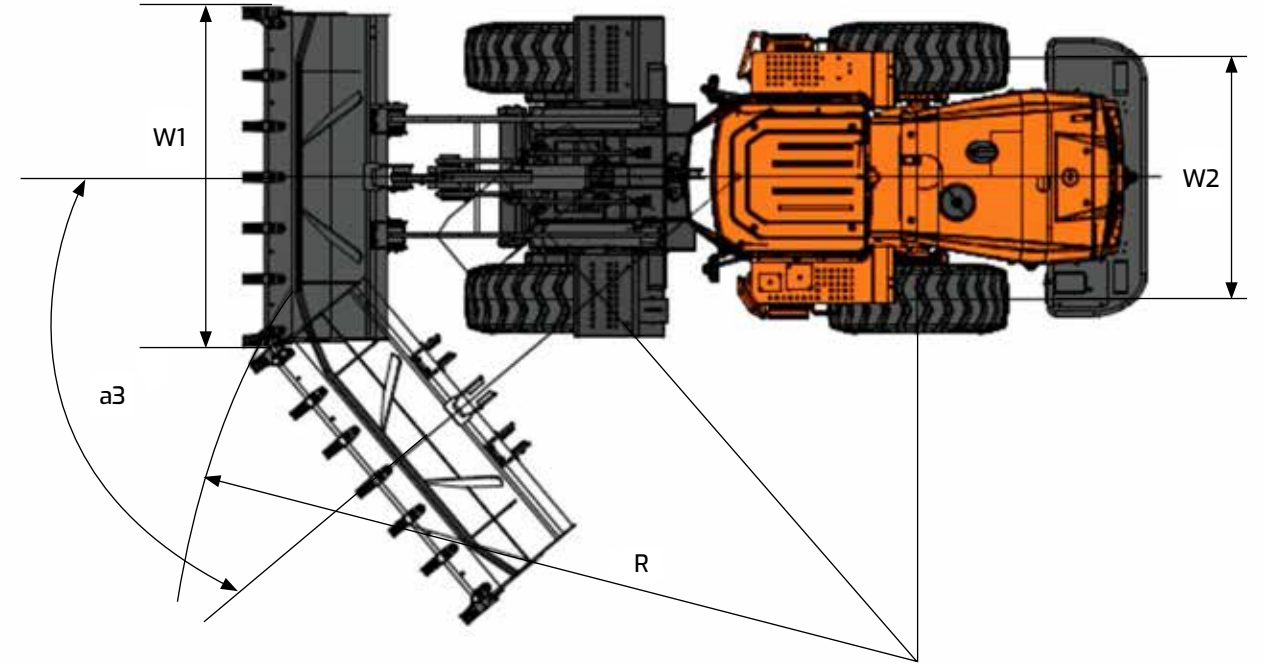
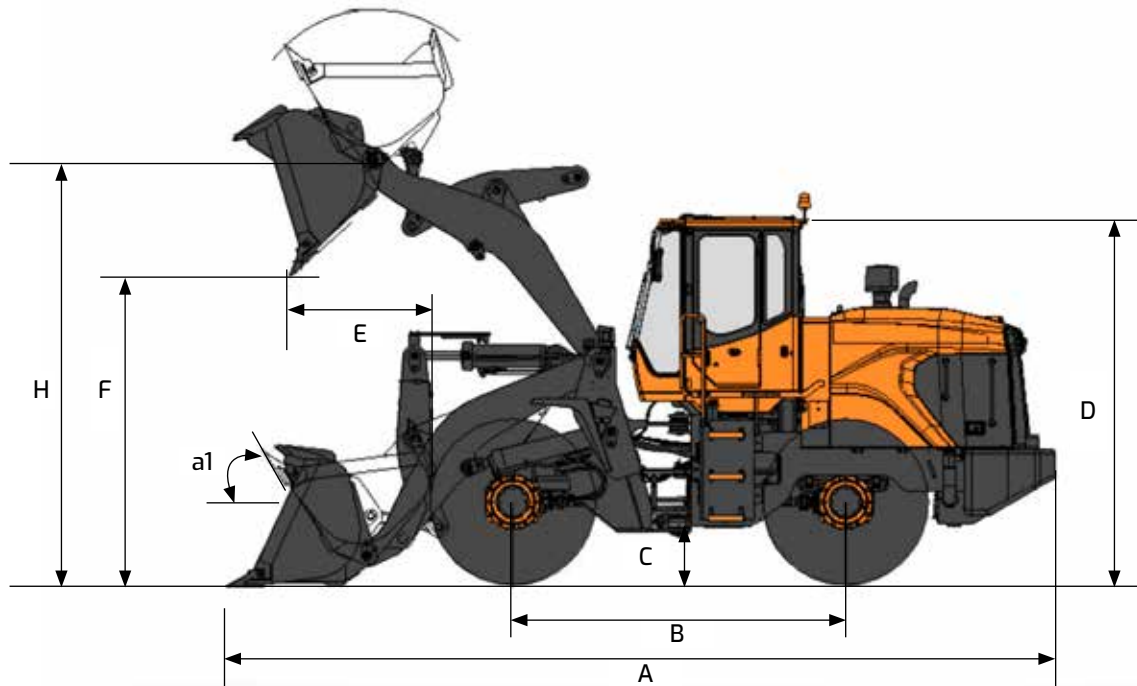

ENGINE

| | |
|-----------------------------------|------------------------------|
| Model | Weichai WD10G220E23 (TIER 2) |
| Rated Power (SAE J1995 Gross) | 162 kW (220ps)@2,000 rpm |
| Max. Torque (SAE J1995 Gross) | 980 N.m@1,300~1,500 rpm |
| Fuel Consumption | 225 g/kW.h@RATED SPEED |
| Number of cylinders/bores/strokes | 6 / 126 mm / 130 mm |
| Displacement | 9.7 L |

HYDRAULIC SYSTEM

| | |
|------------------------|--------------|
| Main Pump Type | Fixed gear |
| Main Pump Displacement | 104.9 cc/rev |
| Max. Flow Rate | 215 l/min |

GENERAL SPECIFICATIONS

| | |
|---|----------------------------|
| Operating Weight | 17 ton |
| Bucket Capacity (SAE HEAPED) | 3.0 m ³ |
| Travel Speed (1/2) | 12.2 / 38 km/h |
| System Pressure (Work/Steer) | 170/140 kg/cm ² |
| Payload | 5,000 kg |
| Static Tipping Load (straight) | 11,300 kg |
| Sound Level in CAB (ISO 6396) | 85 dB (A) |
| External Sound Power Level (2000/14/EC) | 114 dB (A) |
| Fuel Tank Capacity | 300 L |
| Tire Size | 23.5-25-16 PR |

TRANSMISSION

| | |
|-----------------------------------|---|
| Type | 2 Speed, Power-shift, Planet, Engine remote mounted with propeller shaft & damper |
| Torque Converter Stall Ratio/Size | 4.1 / 315 mm |

| ITEMS | UNIT | STD. | OPT 1 | OPT 2 | OPT 3 | | |
|--------------------------------|-----------------------------------|---------|------------|--------|--------|-------|-------|
| Operating Weight | ton | 17 | 17.1 | 17.3 | 17.2 | | |
| Bucket Capacity (SAE HEAPED) | m ³ | 3.0 | 3.0 | 2.7 | 4.0 | | |
| Arm | | STD. | LONG | STD. | STD. | | |
| Breakout Force | kN | 164 | 155.82 | 158.76 | 131.32 | | |
| Dimension | Overall Length | A | mm | 8,020 | 8,445 | 8,122 | 8,107 |
| | Overall Width | W1 | mm | 2,992 | 2,992 | 2,992 | 3,092 |
| | Overall Height | D | mm | 3,520 | 3,520 | 3,520 | 3,520 |
| | Ground Clearance | C | mm | 420 | 420 | 420 | 420 |
| | Wheelbase | B | mm | 3,200 | 3,200 | 3,200 | 3,200 |
| | Tread | W2 | mm | 2,174 | 2,174 | 2,174 | 2,174 |
| Working Range | Dump Height at 45° (with tooth) | F | mm | 3,089 | 3,384 | 3,117 | 3,012 |
| | Dump Reach at 45° (with tooth) | E | mm | 1,308 | 1,366 | 1,335 | 1,276 |
| | Max. Tilt Angle (on ground) | | degree (°) | 45 | 45 | 45 | 45 |
| | Max. Tilt Angle (at fully raised) | | degree (°) | 59 | 59 | 59 | 59 |
| | Max. Tilt Angle (at carry) | a1 | degree (°) | 50 | 50 | 50 | 50 |
| | Height at bucket pivot point | H | mm | 4,150 | 4,450 | 4,150 | 4,150 |
| | Digging Depth (0° level) | | mm | 120 | 200 | 122 | 90 |
| | Max. Steering Angle | a3 | degree (°) | 40 | 40 | 40 | 40 |
| | Turning Radius (tire center) | | mm | 5,630 | 5,630 | 5,630 | 5,630 |
| External radius at bucket edge | R | mm | 6,470 | | | | |
| Gradeability | % (°) | 58 (30) | | | | | |

TECHNICAL SPECIFICATION (SD300H)

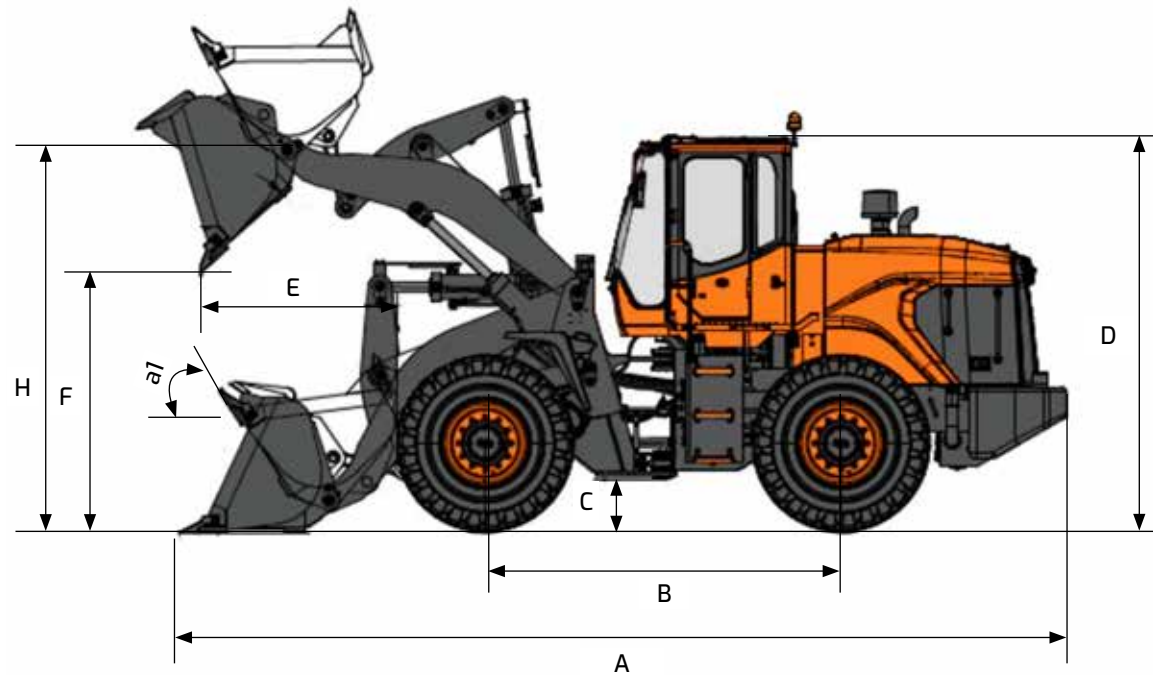

ENGINE

| | |
|-----------------------------------|------------------------------|
| Model | Weichai WD10G220E23 (TIER 2) |
| Rated Power (SAE J1995 Gross) | 162 kW (220 ps)@2,000 rpm |
| Max. Torque (SAE J1995 Gross) | 980 N.m@1,300~1,500 rpm |
| Fuel Consumption | 225 g/kW.h@RATED SPEED |
| Number of cylinders/bores/strokes | 6 / 126 mm / 130 mm |
| Displacement | 9.7 L |

HYDRAULIC SYSTEM

| | |
|------------------------|--------------|
| Main Pump Type | Fixed gear |
| Main Pump Displacement | 104.9 cc/rev |
| Max. Flow Rate | 206 l/min |

GENERAL SPECIFICATIONS

| | |
|---|-------------------------------|
| Operating Weight | 16.4 ton |
| Bucket Capacity (SAE HEAPED) | 3.0 m ³ |
| Travel Speed (1/2/3/4) | 6.3 / 11.4 / 22.7 / 36.5 km/h |
| System Pressure (Work/Steer) | 170/140 kg/cm ² |
| Payload | 3.0 ton |
| Static Tipping Load (straight) | 11,300 kg |
| SOUND LEVEL IN CAB (2000/14/EC) | 85 dB (A) |
| External Sound Power Level (2000/14/EC) | 114 dB (A) |
| Fuel Tank Capacity | 300 L |
| Tire Size | 23.5 - 25 - 16 PR |

TRANSMISSION

| | |
|-----------------------------------|---|
| Type | 4 speed, Power-shift, Countershaft, Engine remote mounted with propeller shaft & damper |
| Torque Converter Stall Ratio/Size | 2.142 / 340 mm |

DIMENSIONS & WORKING RANGE (SD300H)

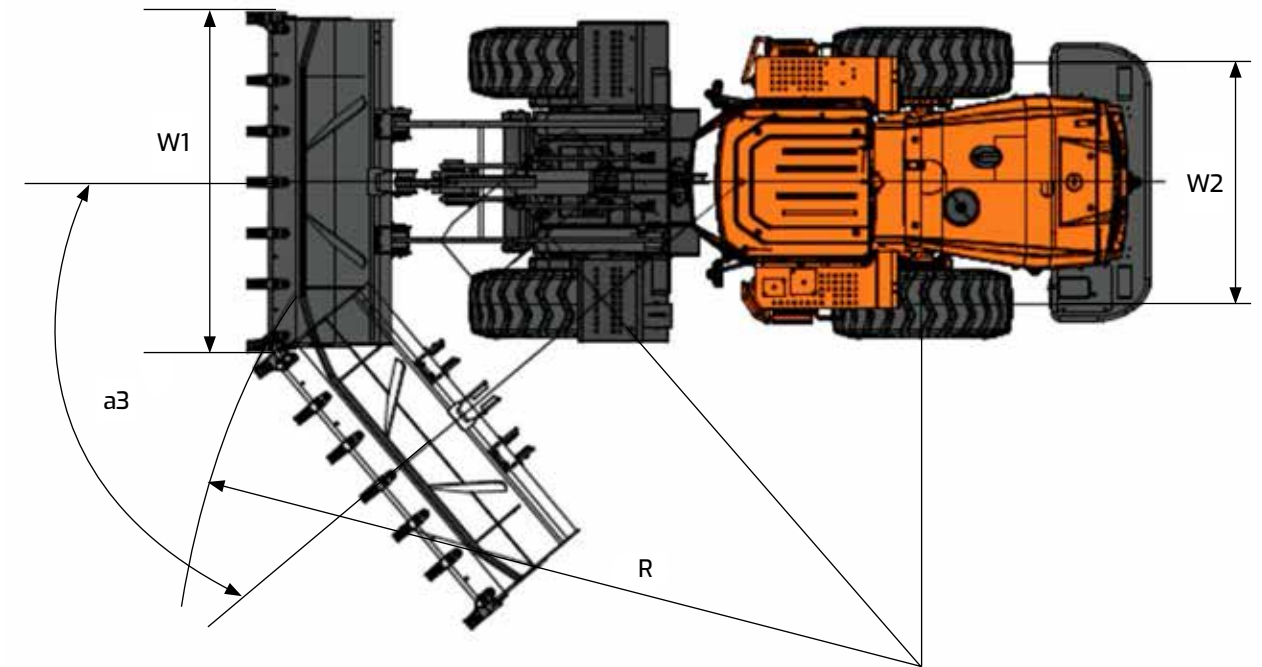

| ITEMS | UNIT | STD. | OPT 1 | OPT 2 | OPT 3 | | |
|--------------------------------|-----------------------------------|---------|------------|--------|-------|-------|-------|
| Operating Weight | ton | 16.9 | 17.2 | 17.2 | 17.0 | | |
| Bucket Capacity (SAE HEAPED) | m ³ | 3.0 | 3.0 | 2.7 | 4.0 | | |
| Arm | | STD. | LONG | STD. | STD. | | |
| Breakout Force | kN | 164 | 161.7 | 164.64 | 161.7 | | |
| Dimension | Overall Length | A | mm | 8,020 | 8,343 | 8,070 | 8,066 |
| | Overall Width | W1 | mm | 2,992 | 2,992 | 2,992 | 2,992 |
| | Overall Height | D | mm | 3,520 | 3,520 | 3,520 | 3,520 |
| | Ground Clearance | C | mm | 420 | 420 | 420 | 420 |
| | Wheelbase | B | mm | 3,200 | 3,200 | 3,200 | 3,200 |
| | Tread | W2 | mm | 2,174 | 2,240 | 2,240 | 2,240 |
| Working Range | Dump Height at 45° (with tooth) | F | mm | 3,089 | 3,380 | 3,090 | 3,010 |
| | Dump Reach at 45° (with tooth) | E | mm | 1,308 | 1,360 | 1,370 | 1,270 |
| | Max. Tilt Angle (on ground) | | degree (°) | 45 | 45 | 45 | 45 |
| | Max. Tilt Angle (at fully raised) | | degree (°) | 60 | 60 | 60 | 60 |
| | Max. Tilt Angle (at carry) | a1 | degree (°) | 50 | 50 | 50 | 50 |
| | Height at bucket pivot point | H | mm | 4,150 | 4,450 | 4,150 | 4,150 |
| | Digging Depth (0° level) | | mm | 120 | 200 | 120 | 89 |
| | Max. Steering Angle | a3 | degree (°) | 40 | 40 | 40 | 40 |
| | Turning Radius (tire center) | | mm | 5,630 | 5,630 | 5,630 | 5,630 |
| External radius at bucket edge | R | mm | 6,470 | | | | |
| Gradeability | % (°) | 58 (30) | | | | | |